



SINGAPORE SWIMMING

SINGAPORE SWIMMING ASSOCIATION

***11th Singapore National
Swimming Championships
26th – 28th Jun 2015***

EVENT INFORMATION

CONTENTS

1.0	COMPETITION INFORMATION	3
2.0	GENERAL INFORMATION	3
3.0	ELIGIBILITY	5
4.0	ENTRY REGULATIONS	5
5.0	DNS/WITHDRAWALS	6
6.0	MEDALS, RECORDS & NATIONAL SELECTION	6
7.0	COMPETITION VENUE	7
8.0	WARM-UP GUIDELINES	8
9.0	PROTESTS	10
10.0	MEET QET - QUALIFYING ENTRY TIMES	11
11.0	ORDER OF EVENTS.....	12

1.0 COMPETITION INFORMATION**Entries Closing Date: Monday, 15th Jun 2015**Technical Meeting for Team Leaders: Thursday, 25th Jun 2015 (11.00am)Competition: 11th Singapore National Swimming Championships 2015

Venue: OCBC Aquatic Centre

Details:	<u>Session</u>	<u>Date</u>	<u>Day</u>	<u>Competition</u>	<u>Warm-Up</u>
	1	26 Jun 2015	Friday	9:30 am	7:45am
	2	26 Jun 2015	Friday	6:30 pm	4:45pm
	3	27 Jun 2015	Saturday	9:30 am	7:45am
	4	27 Jun 2015	Saturday	5:00 pm	3:15pm
	5	28 Jun 2015	Sunday	9:30 am	7:45am
	6	28 Jun 2015	Sunday	5:00 pm	3:15pm

2.0 GENERAL INFORMATION

2.1 The Championships shall be conducted under the Rules and By-laws of FINA as prescribed in the Handbook of FINA. One-start rule applies. The list of approved swimsuits can be viewed at

http://www.fina.org/H2O/index.php?option=com_content&view=category&id=304:fina-approved-swimwear&Itemid=1006

2.2 All entries must be submitted through SSA Affiliates or FINA-affiliated Federations.

2.3 Events listed below will be for both Men and Women:

Freestyle: 50m, 100m, 200m, 400m, 800m(Women) and 1500m(Men)

Backstroke: 50m, 100m and 200m

Breaststroke: 50m, 100m and 200m

Butterfly: 50m, 100m and 200m

Individual Medley: 200m and 400m

Freestyle Relays: 4x100m and 4x200m

Medley Relay: 4x100m

2.4 Technical Officials – All Technical Officials shall be appointed by the SSA Technical Swimming Committee.

2.5 The SNSC Management Committee reserves the right to the final decision on all matters pertaining to the Championships.

2.6 Format of Competition – The Championships are run in the FINA Long-Course Metres (LCM) format. Heats will be run in the morning and Finals in the evening, over 3 consecutive days.

a. Heats
Competitors shall be placed in graduated time order, slowest to fastest and the last three heats shall be cyclically seeded.

b. Finals

Finalists shall be allocated lanes via the spearhead principle from the results of the Heats.

'A' Finals – the top eight (8) **LOCAL** finishers of the Heats of each individual event (With the exception of Timed Final races) is eligible to compete.

"B" Finals – the remaining swimmers, within the top sixteen (16) finishers of the Heats of each individual event who are not eligible to compete in the 'A' Finals (Except the 800m and 1500m Freestyle races) will be able to compete in the "B" Finals. Should there be more than two (2) foreign swimmers who finish within the top ninth-sixteenth (9th -16th) finishers at the Heats, only the top two (2) fastest foreign swimmers would compete in the 'B' Finals.

There will be NO "B" Finals if the event has less than Fourteen (14) swimmers in the Heats.

"C" Finals – the remaining swimmers, within the top twenty four (24) finishers of the Heats of each individual event who are not eligible to compete in the 'A' and 'B' Finals (Except the 800m and 1500m Freestyle races) will be able to compete in the "C" Finals. Should there be more than two (2) foreign swimmers who finish within the top seventeenth-twenty fourth (17th -24th) finishers at the Heats, only the next top two (2) fastest foreign swimmers would compete in the 'C' Finals.

There will be NO "C" Finals if the event has less than Thirty (30) swimmers in the Heats.

Swimmers who missed the Qualifying Entry Time (QET) in the Heats will not be allowed to participate in the Finals.

a. Timed Finals

The 800m and 1500m Freestyle races will be swum as Timed Finals, with the fastest seeded Heat swum during the evening Finals session.

A cut off time of 21 minutes will be enforced for 1500m (both men and women), and a cut off time 11 minutes for 800m (both men & women)

b. Definition of Swimmers:

- All Singapore Citizens are classified as "local swimmers"
- All Non – Singapore Citizens are classified as "foreign swimmers".

3.0 ELIGIBILITY

3.1 The Championships is open to swimmers who are:

- Existing **REGISTERED SWIMMERS** of SSA Affiliates who are of good standing

Registration fee of SGD 30 is applicable to swimmers who have not make the payment for Year 2015. This is also applicable to foreign swimmers.

- Existing members of other National Federations affiliated to FINA who meet the entry qualification standards, provided they hold valid participation clearance from their Federation

3.2 All swimmers must meet the Qualifying Entry Times ("QET") specified for each individual event of the Championships ("race").

3.3 An administrative fee of **S\$25.00** (Heats) shall be imposed if a swimmer returns a time slower than the QET. Swimmers who missed the QET will not be allowed to participate in the Finals.

4.0 ENTRY REGULATIONS

4.1 **Closing date for entries is 12 noon on Monday, 15 June 2015.**

All Entries are to be emailed to edwin.kwee@swimming.org.sg

- a. Late entries will **NOT** be entertained
- b. Performance times from SSA-sanctioned Meets or Overseas Meets dated from 1 June 2014 to 25 June 2015 can be used as entry time for 11th SNSC 2015.
- c. To participate, swimmers must meet the Qualifying Entry Times (QET) in the respective events. Entries with no QET, times slower than QET and false times will be rejected. SSA reserves the right to contact the club administrators for verification of entry times.
- d. An administrative fee of **S\$25.00** per event will be imposed if a swimmer returns a time slower than the QET.
- e. Participants who missed the QET in the Heats will not be allowed to participate in the Finals.
- f. Entries must be accompanied by full payment of the registration and entries fees by **5.00pm, Friday 19th June 2015.** Swimmers **will not be eligible to compete** if the full payment does not reach Singapore Swimming Association by the above deadline.

- 4.3 Entry Fees
 a. Individual – **S\$10.00** per event (inc GST)
 b. Relays – **S\$20.00** per event (inc GST)

- 4.4 Cheques for all registration and entries are to be made payable to “**Singapore Swimming Association**” by **5.00pm Friday, 19th June 2015**.

If payment for the entry fee is not made on time, the entries **will not** be accepted.

- 4.5 It is **mandatory** for swimmer’s entries to be accompanied with NRIC (Singaporeans/PR) or passport number (foreigner). LAST name (Surname) is to be provided in CAPITAL LETTERS.

Incomplete/Erroneous entries will be rejected.

Example:

Last Name (Surname)	First Name	Gender	Date of Birth	NRIC
TAN	Ah Lian, Susan	F	20-May-1997	S9734567F
LIM	Poh Poh	M	19-Apr-2000	T0012345C

**Do note that club's membership number should not be filled up in the NRIC column*

- 4.6 As an administrative incentive, SSA will extend a 10% discount off the total entry fees due to Affiliates which submit entries electronically via the Hy-Tek Sports Software’s *Team Manager* format by **Monday, 15th Jun 2015**. Affiliates which do not own the software may download a free version *Team Manager Lite* from <http://www.hy-tek.com/downloads.html>.

- 4.6 There will be no limit to the number of entries for each swimmer provided all entries comply with the conditions for this competition.

5.0 DNS/WITHDRAWALS

- 5.1 An administrative fee of **S\$25.00** shall be imposed on each withdrawal from entered events.
- 5.2 Team Leaders must present withdrawals to the Control Room Supervisor sixty (60) minutes prior to the start of the heats. Withdrawals for finals **including** the Reserve Swimmers of each event must be presented to the Control Room Supervisor **within 30 minutes of the posting of the heats result**.
- 5.3 Withdrawals within sixty (60) minutes of the start of each session (Heats or Finals) or without notification to the Control Room Supervisor shall be deemed Did Not Show or Did Not Start (DNS). A penalty of **S\$100.00** shall be imposed on all DNS.

- 5.4 The administrative fee and penalty will be waived if the swimmer produces a valid medical certificate for the relevant day of the race. However, the swimmer will not be permitted to participate in all races for the day.

6.0 MEDALS, RECORDS & NATIONAL SELECTION

- 6.1 Medals will be awarded to the top three Singaporean swimmers in the 'A' Finals.

The Most Valuable Swimmer Award will be given out to each male and female Singaporean swimmer who has the highest accumulated no. of FINA Points; from a maximum of 3 Olympic events in this competition.

- 6.2 Overall Club Performance shall be based on the total amount of points scored.

- 6.3 The Relay events score double points.

- 6.4 Position Points awarded:

Places 1-16: 20-17-16-15-14-13-12-11-9-7-6-5-4-3-2-1
Relays 1-8: 40-34-32-30-28-26-24-22

- 6.5 Only Meet Records established by Singaporeans will be officially recognised by the Organising Committee of the 11th Singapore National Swimming Championships

- 6.6 Age computation, for the purpose of Under-14 and Under-17 National Records recognition, will be based on age of swimmer on the day of record set.

- 6.7 The following Challenge trophies (Singapore Citizens only) will be awarded:

Challenge Trophy	- SSA Affiliate with the most points
Neo Chwee Kok Cup	- 100m Freestyle Men's Champion
Chan Ah Kow Cup	- 100m Butterfly Men's Champion
Kee Soon Bee Cup	- 400m Freestyle Women's Champion

7.0 COMPETITION VENUE

View Map: <http://www.sportshub.com.sg/directions/Pages/getting-here.aspx>



8.0 WARM-UP GUIDELINES

8.1 The Competition and Warm-Up Pools will be available for warm-ups one and the half hour before the competitions commence. The Competition Pool will be closed fifteen (15) minutes before the beginning of each session.

8.2 Lane assignments for warm-ups will be in accordance with FINA Swimming Rules

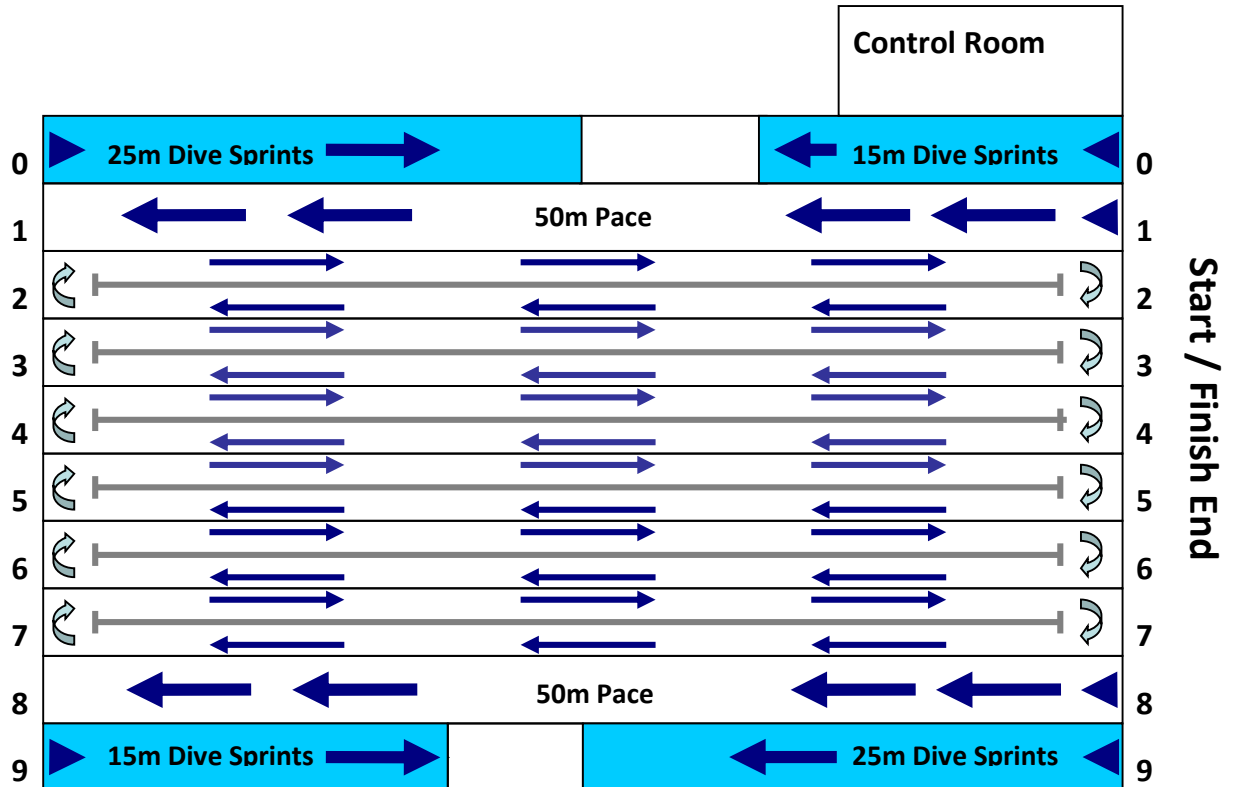

8.3 Competition Pool:

- a. The schematic in the diagram shall be observed at all times during warm-ups.
- b. There shall be **NO DIVING** in the Circle Swimming Lanes, the Turn Practice Lanes, and the 50m Pace Lane (opposite side). Entry to these lanes is via feet first entry from the sitting position at all times.
- c. The use of swim paddles is prohibited during warm-up.
- d. The Dive Sprint Lanes are one-way only – swimmers should clear the lanes immediately and walk back. Swimmers are advised to exercise caution when doing Backstroke starts.

- e. Coaches and Team Officials will be allowed on the Competition Pool Deck during the warm-up sessions.
- f. In order to ensure a smooth Swimming Competition Time-Lines Compliance, eliminate unnecessary downtime due to infraction enquiry to the Referee, promote Fair Play during the Swimming Competition and eliminate Technical Officials duty obstruction , the Pool Deck is strictly out of bound to ALL except the Technical Officials on duty, Swimming Competition Management Committee, Appointed Volunteer, Appointed Media Coverage Personnel.

8.4 Warm-Up Pool:

- a. The Warm-Up Pool will be **CIRCLE SWIMMING ONLY**, with feet first entry from sitting position at all times
- b. The use of swim paddles is prohibited during warm-up.

9.0 Control Room Guidelines (Infraction Enquiry or Clarification)

- a. Detail of Infraction committed by swimmer or swimmers shall be made to the Swimming Competition Meet Director by the Team Leader. No proxies will be entertained.
- b. In the absence of Meet Director, infraction enquiry shall be directed only to the Deputy Meet Director or Control Room Supervisor.
- c. Enquiry of infraction shall be made within the same day of competition.
- d. Team Leader shall provide Swimmer Details ie Event Number, Heat Number, Swimmer's Name, Affiliate Name and Lane assigned.
- e. **ONLY** Team Leader shall be allowed access to Swimming Competition Control Room to retrieve final result print-outs, submission of necessary paperwork and Infraction Enquiry. No proxies shall be allowed.

10.0 PROTESTS

10.1 Protests are possible:

- a. if the rules and regulations for the conduct of the competition are not observed,
- b. if other conditions endanger the competitions and/or competitors, or
- c. against decisions of the referee; however, no protest shall be allowed against decisions of fact.

10.2 All protests shall be considered by the Meet Referee. However, protests against decisions of fact shall not be allowed.

10.3 If conditions causing a potential protest are noted prior to the competition, a protest must be lodged before the signal to start the race is given.

10.4 Protests must be submitted in accordance with the following:

- a. In writing, with the supporting facts.
- b. With a deposit of **S\$100.00** enclosed.
- c. Submitted to the Meet Referee by Affiliate Team Leader. No proxies will be entertained.
- d. Submitted within thirty (30) minutes following the conclusion of the respective event.

10.5 If the Meet Referee rejects the protest, he/she must state the reasons for his decision. The Team Leader may then appeal the rejection to the Jury of Appeal, whose decision shall be final.

10.6 If the protest is rejected, the deposit shall be forfeited to the SNSC Management Committee. If the protest is upheld, the deposit shall be returned.

11.0 MEET QET - QUALIFYING ENTRY TIMES

MEN	QET	WOMEN	QET
50m Freestyle	27.86	50m Freestyle	30.96
100m Freestyle	1:01.21	100m Freestyle	1:07.94
200m Freestyle	2:15.62	200m Freestyle	2:27.43
400m Freestyle	4:47.18	400m Freestyle	5:11.70
1500m Freestyle	19:40.71	800m Freestyle	11:02.53
50m Backstroke	35.18	50m Backstroke	35.31
100m Backstroke	1:14.76	100m Backstroke	1:15.84
200m Backstroke	2:39.69	200m Backstroke	2:44.46
50m Breaststroke	36.30	50m Breaststroke	38.85
100m Breaststroke	1:19.04	100m Breaststroke	1:24.52
200m Breaststroke	2:54.18	200m Breaststroke	3:04.82
50m Butterfly	30.47	50m Butterfly	32.71
100m Butterfly	1:07.37	100m Butterfly	1:13.10
200m Butterfly	2:37.39	200m Butterfly	2:42.98
200m Individual Medley	2:33.64	200m Individual Medley	2:44.62
400m Individual Medley	5:33.00	400m Individual Medley	5:54.62
4x100m Freestyle Relay	4:05.64	4x100m Freestyle Relay	4:36.28
4x200m Freestyle Relay	9:06.18	4x200m Freestyle Relay	10:02.99
4x100m Medley Relay	4:30.49	4x100m Medley Relay	5:02.81

12.0 ORDER OF EVENTS

26th Jun 2015 (Friday) – Day 1				
Heats Start Time: 9.30am				
Event No	Event			Remarks
101	400m FREESTYLE	MEN	HEATS	
102	400m FREESTYLE	WOMEN	HEATS	
103	50m BREASTSTROKE	MEN	HEATS	
104	50m BREASTSTROKE	WOMEN	HEATS	
105	100m BACKSTROKE	MEN	HEATS	
106	100m BACKSTROKE	WOMEN	HEATS	
107	100m BUTTERFLY	MEN	HEATS	
108	100m BUTTERFLY	WOMEN	HEATS	
109	200M INDIVIDUAL MEDLEY	MEN	HEATS	
110	200M INDIVIDUAL MEDLEY	WOMEN	HEATS	
111	50M FREESTYLE	MEN	HEATS	
112	50M FREESTYLE	WOMEN	HEATS	
113	4 X 200M FREESTYLE RELAYS	MEN	HEATS	
114	4 X 200M FREESTYLE RELAYS	WOMEN	HEATS	
26th Jun 2015 (Friday) – Day 1				
Finals Start Time: 6.30pm				
101	400m FREESTYLE	MEN	A, B & C FINALS	
102	400m FREESTYLE	WOMEN	A, B & C FINALS	
103	50m BREASTSTROKE	MEN	A, B & C FINALS	
104	50m BREASTSTROKE	WOMEN	A, B & C FINALS	
<i>Victory Ceremony for #101, #102 & #103</i>				
105	100m BACKSTROKE	MEN	A, B & C FINALS	
106	100m BACKSTROKE	WOMEN	A, B & C FINALS	
107	100m BUTTERFLY	MEN	A, B & C FINALS	
108	100m BUTTERFLY	WOMEN	A, B & C FINALS	
<i>Victory Ceremony for #104, #105, #106 & #107</i>				
109	200M INDIVIDUAL MEDLEY	MEN	A, B & C FINALS	
110	200M INDIVIDUAL MEDLEY	WOMEN	A, B & C FINALS	
111	50M FREESTYLE	MEN	A, B & C FINALS	
112	50M FREESTYLE	WOMEN	A, B & C FINALS	
<i>Victory Ceremony for #108, #109, #110 & #111</i>				
113	4 X 200M FREESTYLE RELAYS	MEN	FINALS	
114	4 X 200M FREESTYLE RELAYS	WOMEN	FINALS	
<i>Victory Ceremony for 112, #113 & #114</i>				

11th Singapore National Swimming Championships 2015

27th Jun 2015 (Saturday) – Day 2				
Heats Start Time: 9.30am				
Event No	Event			Remarks
201	200M FREESTYLE	MEN	HEATS	
202	200M FREESTYLE	WOMEN	HEATS	
203	50M BUTTERFLY	MEN	HEATS	
204	50M BUTTERFLY	WOMEN	HEATS	
205	100m BREASTSTROKE	MEN	HEATS	
206	100m BREASTSTROKE	WOMEN	HEATS	
207	200m BACKSTROKE	MEN	HEATS	
208	200m BACKSTROKE	WOMEN	HEATS	
209	400M INDIVIDUAL MEDLEY	MEN	HEATS	
210	400M INDIVIDUAL MEDLEY	WOMEN	HEATS	
211	4X100M FREESTYLE RELAYS	MEN	HEATS	
212	4X100M FREESTYLE RELAYS	WOMEN	HEATS	
27th Jun 2015 (Saturday) – Day 2				
Finals Start Time: 5.00pm				
201	200M FREESTYLE	MEN	A, B & C FINALS	
202	200M FREESTYLE	WOMEN	A, B & C FINALS	
203	50M BUTTERFLY	MEN	A, B & C FINALS	
204	50M BUTTERFLY	WOMEN	A, B & C FINALS	
205	100m BREASTSTROKE	MEN	A, B & C FINALS	
<i>Victory Ceremony for #201, #202, #203 & #204</i>				
206	100m BREASTSTROKE	WOMEN	A, B & C FINALS	
207	200m BACKSTROKE	MEN	A, B & C FINALS	
208	200m BACKSTROKE	WOMEN	A, B & C FINALS	
209	400M INDIVIDUAL MEDLEY	MEN	A, B & C FINALS	
<i>Victory Ceremony for #205, #206, #207 & #208</i>				
210	400M INDIVIDUAL MEDLEY	WOMEN	A, B & C FINALS	
211	4X100M FREESTYLE RELAYS	MEN	FINALS	
212	4X100M FREESTYLE RELAYS	WOMEN	FINALS	
<i>Victory Ceremony for #209, #210, #211 & #212</i>				

11th Singapore National Swimming Championships 2015

28th Jun 2015 (Sunday) – Day 3				
Heats Start Time: 9.30am				
Event No	Event			Remarks
303	50M BACKSTROKE	MEN	HEATS	
304	50M BACKSTROKE	WOMEN	HEATS	
305	100m FREESTYLE	MEN	HEATS	
306	100m FREESTYLE	WOMEN	HEATS	
307	200M BREASTSTROKE	MEN	HEATS	
308	200M BREASTSTROKE	WOMEN	HEATS	
309	200M BUTTERFLY	MEN	HEATS	
310	200M BUTTERFLY	WOMEN	HEATS	
311	4 X 100M MEDLEY RELAY	MEN	HEATS	
312	4 X 100M MEDLEY RELAY	WOMEN	HEATS	
301	1500M FREESTYLE	MEN	T.FINALS	SLOWER HEATS IN THE MORNING
302	800m FREESTYLE	WOMEN	T. FINALS	SLOWER HEATS IN THE MORNING
28th Jun 2015 (Sunday) – Day 3				
Finals Start Time: 5.00pm				
301	1500M FREESTYLE	MEN	T. FINALS	FASTEST HEATS IN THE EVENING
302	800m FREESTYLE	WOMEN	T. FINALS	FASTEST HEATS IN THE EVENING
303	50M BACKSTROKE	MEN	A, B & C FINALS	
304	50M BACKSTROKE	WOMEN	A, B & C FINALS	
305	100m FREESTYLE	MEN	A, B & C FINALS	
<i>Victory Ceremony for #301, #302, #303 & #304</i>				
306	100m FREESTYLE	WOMEN	A, B & C FINALS	
307	200M BREASTSTROKE	MEN	A, B & C FINALS	
308	200M BREASTSTROKE	WOMEN	A, B & C FINALS	
309	200M BUTTERFLY	MEN	A, B & C FINALS	
<i>Victory Ceremony for #305, #306, #307 & #308</i>				
310	200M BUTTERFLY	WOMEN	A, B & C FINALS	
311	4 X 100M MEDLEY RELAY	MEN	FINALS	
312	4 X 100M MEDLEY RELAY	WOMEN	FINALS	
<i>Victory Ceremony for #309, #310, #311 & #312</i>				

KEY DATES

Date & Time	Event	Venue
15 Jun 2015	Closing Date for Entries Submission Note: Late entries will not be entertained	SSA Office or via email edwin.kwee@swimming.org.sg
16 - 19 Jun 2015	Entries list by affiliates/ teams will be sent for verification	
19 Jun 2015	Deadline for Payment for Entries	
22 Jun 2015, 5.00pm	Preliminary Entries List (Psych Sheet) will be sent out to all participating affiliates/teams	
25 Jun 2015, 11.00am	Team Leaders Meeting	OCBC Aquatic Centre Technical Control Room
26 - 28 Jun 2015	11 th Singapore National Swimming C'ships 2015	OCBC Aquatic Centre