



SINGAPORE SWIMMING

SINGAPORE SWIMMING ASSOCIATION

***5th Singapore National
Swimming Championships (Short Course
Meet)
18th – 19th Dec 2015***

EVENT INFORMATION

CONTENTS

1.0	COMPETITION INFORMATION	3
2.0	GENERAL INFORMATION	3
3.0	ELIGIBILITY	5
4.0	ENTRY REGULATIONS	5
5.0	DNS/WITHDRAWALS	6
6.0	MEDALS, RECORDS & NATIONAL SELECTION	7
7.0	COMPETITION VENUE	8
8.0	WARM-UP GUIDELINES	9
9.0	CONTROL ROOM GUIDELINES.....	10
10.0	PROTESTS.....	11
11.0	MEET QET - QUALIFYING ENTRY TIMES.....	12
12.0	ORDER OF EVENTS.....	13
13.0	TERMS AND CONDITIONS.....	16
14.0	KEY DATES.....	17

1.0 COMPETITION INFORMATION**Entries Closing Date: Wednesday, 9th Dec 2015**Technical Meeting for Team Leaders: Thursday, 17th Dec 2015 (11.00am)Competition: 5th Singapore National Swimming Championships (SCM) 2015

Venue: OCBC Aquatic Centre

Details:	<u>Session</u>	<u>Date</u>	<u>Day</u>	<u>Competition</u>	<u>Warm-Up</u>
	1	18 Dec 2015	Friday	9:30 am	7:45am
	2	18 Dec 2015	Friday	6:30 pm	4:45pm
	3	19 Dec 2015	Saturday	9:30 am	7:45am
	4	19 Dec 2015	Saturday	5:00 pm	3:15pm

2.0 GENERAL INFORMATION

2.1 The Championships shall be conducted under the Rules and By-laws of FINA as prescribed in the Handbook of FINA. One-start rule applies. The list of approved swimsuits can be viewed at

http://www.fina.org/H2O/index.php?option=com_content&view=category&id=304:fina-approved-swimwear&Itemid=1006

2.2 All entries must be submitted through SSA Affiliates or FINA-affiliated Federations.

2.3 Events listed below will be for both Men and Women:

Freestyle: 50m, 100m, 200m, 400m, 800m(Women) and 1500m(Men)

Backstroke: 50m, 100m and 200m

Breaststroke: 50m, 100m and 200m

Butterfly: 50m, 100m and 200m

Individual Medley: 100m,200m and 400m

Freestyle Relays: 4x50m (Mixed)

Medley Relay: 4x50m (Mixed)

2.4 Technical Officials – All Technical Officials shall be appointed by the SSA Technical Swimming Committee.

2.5 The SNSC Management Committee reserves the right to the final decision on all matters pertaining to the Championships.

2.6 Format of Competition – The Championships are run in the FINA Short-Course Metres (SCM) format. Heats will be run in the morning and Finals in the evening, over 2 consecutive days.

- a. Heats
Competitors shall be placed in graduated time order, slowest to fastest and the last three heats shall be cyclically seeded.

- b. Finals

Finalists shall be allocated lanes via the spearhead principle from the results of the Heats.

'A' Finals – the top eight (8) finishers of the Heats of each individual event (With the exception of Timed Final races) is eligible to compete. Should there be more than three (3) foreign swimmers who finish within the top eight (8) positions at the Heats, only the top three (3) fastest foreign swimmers would compete in the 'A' Finals.

"B" Finals – the remaining swimmers, within the top sixteen (16) finishers of the Heats of each individual event who are not eligible to compete in the 'A' Finals (Except the 400m IM, 800m Freestyle and 1500m Freestyle races) will be able to compete in the "B" Finals. Should there be more than three (3) foreign swimmers who finish within the top ninth-sixteenth (9th -16th) finishers at the Heats, only the top three (3) fastest foreign swimmers would compete in the 'B' Finals. There will be NO "B" Finals if the event has less than Fourteen (14) swimmers in the Heats.

Swimmers who missed the Qualifying Entry Time (QET) in the Heats will not be allowed to participate in the Finals.

- c. Timed Finals

The 400m IM, 800m Freestyle and 1500m Freestyle races will be swum as Timed Finals, with the fastest seeded Heat swum during the evening Finals session. A cut off time of 21 minutes will be enforced for 1500m (both men and women), and a cut off time 11 minutes for 800m (both men & women)

- d. Mixed Relay

The rules for the Mixed Relays are the same as for gender relays except that the Mixed Relays must consist of two (2) Male and two (2) Female swimmers. The starting order of the swimmers is decided by each team. Swimmers must be competing in individual events to be eligible to participate in the mixed relay. Affiliates are allowed to send in more than one team per event.

- e. Definition of Swimmers:

- Local Swimmers- All Affiliated Member with a Valid Singapore NRIC or FIN#
- Foreign Swimmers- All Swimmers without a Valid Singapore NRIC or FIN#

3.0 ELIGIBILITY

3.1 The Championships is open to swimmers who are:

- Existing **REGISTERED SWIMMERS** of SSA Affiliates who are of good standing

Registration fee of SGD 30 is applicable to swimmers who have not make the payment for Year 2015. This is also applicable to foreign swimmers.

- Existing members of other National Federations affiliated to FINA who meet the entry qualification standards, provided they hold valid participation clearance from their Federation

3.2 All swimmers must meet the Qualifying Entry Times ("QET") specified for each individual event of the Championships ("race").

3.3 An administrative fee of **S\$25.00** (Heats) shall be imposed if a swimmer returns a time slower than the QET. Swimmers who missed the QET will not be allowed to participate in the Finals.

4.0 ENTRY REGULATIONS

4.1 **Closing date for entries is 12 noon on Wednesday, 9 Dec 2015**

All Entries are to be emailed to edwin.kwee@swimming.org.sg

- a. Late entries will **NOT** be entertained
- b. Performance times from SSA-sanctioned Meets or Overseas Meets dated from 16 Dec 2014 to 8 Dec 2015 can be used as an entry time for 5th SNSC 2015 (SCM)
- c. To participate, swimmers must meet the Qualifying Entry Times (QET) in the respective events. Entries with no QET, times slower than QET and false times will be rejected. SSA reserves the right to contact the club administrators for verification of entry times.
- d. An administrative fee of **S\$25.00** per event will be imposed if a swimmer returns a time slower than the QET.
- e. Participants who missed the QET in the Heats will not be allowed to participate in the Finals.

- f. Entries must be accompanied by full payment of the registration and entries fees by **5.00pm, 11th Dec 2015**. Swimmers **will not be eligible to compete** if the full payment does not reach Singapore Swimming Association by the above deadline.

4.3 Entry Fees

- a. Individual – **S\$6.00** per event (inc GST)
- b. Relays – **S\$22.00** per event (inc GST)

4.4 Cheques for all registration and entries are to be made payable to “**Singapore Swimming Association**” by **5.00pm Friday, 11th December 2015**.

If payment for the entry fee is not made on time, the entries **will not** be accepted.

- 4.5 It is **mandatory** for swimmer’s entries to be accompanied with NRIC (Singaporeans/PR) or passport number (foreigner). LAST name (Surname) is to be provided in CAPITAL LETTERS.

Incomplete/Erroneous entries will be rejected.

Example:

Last Name (Surname)	First Name	Gender	Date of Birth	NRIC
TAN	Ah Lian, Susan	F	20-May-1997	S9734567F
LIM	Poh Poh	M	19-Apr-2000	T0012345C

**Do note that club's membership number should not be filled up in the NRIC column*

- 4.6 As an administrative incentive, SSA will extend a 10% discount off the total entry fees due to Affiliates which submit entries electronically via the Hy-Tek Sports Software’s *Team Manager* format by **Wednesday, 9th Dec 2015** Affiliates which do not own the software may download a free version *Team Manager Lite* from <http://www.hy-tek.com/downloads.html>.
- 4.7 There will be no limit to the number of entries for each swimmer provided all entries comply with the conditions for this competition.

5.0 DNS/WITHDRAWALS

- 5.1 An administrative fee of **S\$25.00** shall be imposed on each withdrawal from entered events.
- 5.2 Team Leaders must present withdrawals to the Control Room Supervisor sixty (60) minutes prior to the start of the heats. Withdrawals for finals **including** the Reserve Swimmers of each event must be presented to the Control Room Supervisor **within 30 minutes of the posting of the heats result**.

- 5.3 Withdrawals within sixty (60) minutes of the start of each session (Heats or Finals) or without notification to the Control Room Supervisor shall be deemed Did Not Show or Did Not Start (DNS). A penalty of **S\$100.00** shall be imposed on all DNS.
- 5.4 The administrative fee and penalty will be waived if the swimmer produces a valid medical certificate for the relevant day of the race. However, the swimmer will not be permitted to participate in all races for the day.

6.0 MEDALS, RECORDS & NATIONAL SELECTION

- 6.1 Medals will be awarded to the top three (3) placings in all the events.
- 6.2 Medals will be awarded to the top three Singaporean swimmers* in the individual events (these medals will only be given out after the event).
- 6.3 Records established by **Singaporean Swimmers** will be officially recognised by the Management Committee of the 5th Singapore National Swimming Championships (Short Course Meters) 2015 as the **“Meet Record”**.
- 6.4 Records established by any Swimmers (Singaporean Swimmers and Non-Singaporean Swimmers) will be officially recognised by the Management Committee of the 5th Singapore National Swimming Championships (Short Course Meters) 2015 as the **“Open Record”**.

*Singaporean Swimmer- Swimmers who hold a Pink IC

7.0 COMPETITION VENUE

7.1 View Map: <http://www.sportshub.com.sg/directions/Pages/getting-here.aspx>



7.2 As per instruction from the Venue Management, please take note that Foldable chairs/mats and outside food/beverage is not allowed into the OCBC Aquatic Centre Spectator Stand. Foldable chairs/mats are not allowed into the OCBC Aquatic Centre Spectator Stand due to the Fire Safety Regulation.

The Venue Management has updated that the booths from Sports Catering Services booth will be open during events held at OCBC AQC.

8.0 WARM-UP GUIDELINES

- 8.1 The Competition and Warm-Up Pools will be available for warm-ups one and the half hour before the competitions commence. The Competition Pool will be closed fifteen (15) minutes before the beginning of each session.
- 8.2 Lane assignments for warm-ups will be in accordance with FINA Swimming Rules

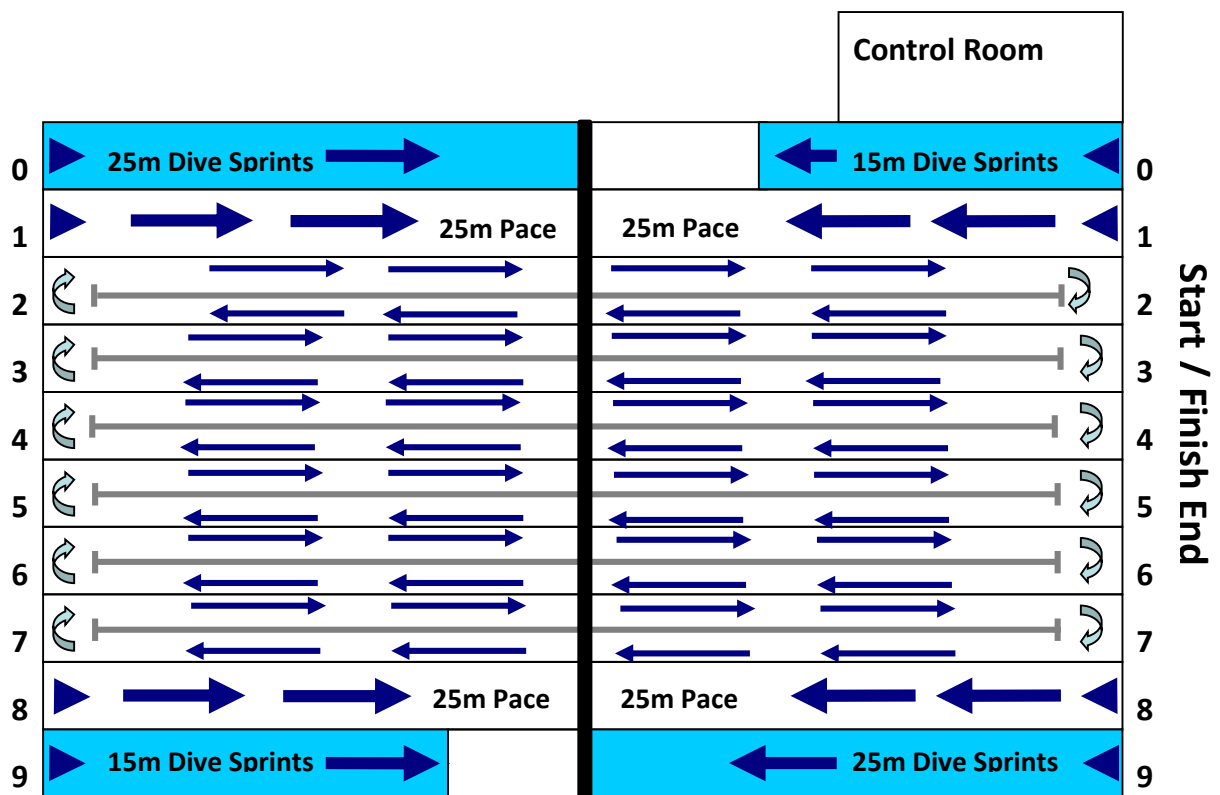

8.3 Competition Pool:

- a. The schematic in the diagram shall be observed at all times during warm-ups.
- b. There shall be **NO DIVING** in the Circle Swimming Lanes, the Turn Practice Lanes, and the 25m Pace Lane (opposite side). Entry to these lanes is via feet first entry from the sitting position at all times.
- c. The use of swim paddles is prohibited during warm-up.

- d. The Dive Sprint Lanes are one-way only – swimmers should clear the lanes immediately and walk back. Swimmers are advised to exercise caution when doing Backstroke starts.
- e. Coaches and Team Officials will be allowed on the Competition Pool Deck during the warm-up sessions.
- f. In order to ensure a smooth Swimming Competition Time-Lines Compliance, eliminate unnecessary downtime due to infraction enquiry to the Referee, promote Fair Play during the Swimming Competition and eliminate Technical Officials duty obstruction , the Pool Deck is strictly out of bound to ALL except the Technical Officials on duty, Swimming Competition Management Committee, Appointed Volunteer, Appointed Media Coverage Personnel.

8.4 Warm-Up Pool:

- a. The Warm-Up Pool will be **CIRCLE SWIMMING ONLY**, with feet first entry from sitting position at all times
- b. The use of swim paddles is prohibited during warm-up.

9.0 Control Room Guidelines (Infraction Enquiry or Clarification)

- a. Detail of Infraction committed by swimmer or swimmers shall be made to the Swimming Competition Meet Director by the Team Leader. No proxies will be entertained.
- b. In the absence of Meet Director, infraction enquiry shall be directed only to the Deputy Meet Director or Control Room Supervisor.
- c. Enquiry of infraction shall be made within the same day of competition.
- d. Team Leader shall provide Swimmer Details ie Event Number, Heat Number, Swimmer's Name, Affiliate Name and Lane assigned.
- e. **ONLY** Team Leader shall be allowed access to Swimming Competition Control Room to retrieve final result print-outs, submission of necessary paperwork and Infraction Enquiry. No proxies shall be allowed.

10.0 PROTESTS

- 10.1 Protests are possible:
- a. if the rules and regulations for the conduct of the competition are not observed,
 - b. if other conditions endanger the competitions and/or competitors, or
 - c. against decisions of the referee; however, no protest shall be allowed against decisions of fact.
- 10.2 All protests shall be considered by the Meet Referee. However, protests against decisions of fact shall not be allowed.
- 10.3 If conditions causing a potential protest are noted prior to the competition, a protest must be lodged before the signal to start the race is given.
- 10.4 Protests must be submitted in accordance with the following:
- a. In writing, with the supporting facts.
 - b. With a deposit of **S\$100.00** enclosed.
 - c. Submitted to the Meet Referee by Affiliate Team Leader. No proxies will be entertained.
 - d. Submitted within thirty (30) minutes following the conclusion of the respective event.
- 10.5 If the Meet Referee rejects the protest, he/she must state the reasons for his decision. The Team Leader may then appeal the rejection to the Jury of Appeal, whose decision shall be final.
- 10.6 If the protest is rejected, the deposit shall be forfeited to the SNSC Management Committee. If the protest is upheld, the deposit shall be returned.

11.0 MEET QET - QUALIFYING ENTRY TIMES

MEN	QET	WOMEN	QET
50m Freestyle	27.86	50m Freestyle	30.96
100m Freestyle	1:01.21	100m Freestyle	1:07.94
200m Freestyle	2:15.62	200m Freestyle	2:27.43
400m Freestyle	4:47.18	400m Freestyle	5:11.70
1500m Freestyle	19:40.71	800m Freestyle	11:02.53
50m Backstroke	35.18	50m Backstroke	35.31
100m Backstroke	1:14.76	100m Backstroke	1:15.84
200m Backstroke	2:39.69	200m Backstroke	2:44.46
50m Breaststroke	36.30	50m Breaststroke	38.85
100m Breaststroke	1:19.04	100m Breaststroke	1:24.52
200m Breaststroke	2:54.18	200m Breaststroke	3:04.82
50m Butterfly	30.47	50m Butterfly	32.71
100m Butterfly	1:07.37	100m Butterfly	1:13.10
200m Butterfly	2:37.39	200m Butterfly	2:42.98
100m Individual Medley	1:08.85	100m Individual Medley	1:18.00
200m Individual Medley	2:33.64	200m Individual Medley	2:44.62
400m Individual Medley	5:33.00	400m Individual Medley	5:54.62
*4x50m Freestyle Relay (Mixed)	NIL	*4x50m Freestyle Relay (Mixed)	NIL

*Swimmers must be competing in individual events to be eligible to participate in the mixed relay.

12.0 ORDER OF EVENTS

18th Dec 2015 (Friday) – Day 1				
Heats Start Time: 9.30am				
<i>Event No</i>	<i>Event</i>			<i>Remarks</i>
103	100M FREESTYLE	MEN	HEATS	
104	200M FREESTYLE	WOMEN	HEATS	
105	50M BREASTSTROKE	MEN	HEATS	
106	100M BREASTSTROKE	WOMEN	HEATS	
107	100M BUTTERFLY	WOMEN	HEATS	
108	100M BACKSTROKE	MEN	HEATS	
109	50M BACKSTROKE	WOMEN	HEATS	
110	200M BUTTERFLY	MEN	HEATS	
111	200M INDIVIDUAL MEDLEY	WOMEN	HEATS	
112	400M FREESTYLE	MEN	HEATS	
113	50M FREESTYLE	WOMEN	HEATS	
114	200M BREASTSTROKE	MEN	HEATS	
115	100M INDIVIDUAL MEDLEY	MEN	HEATS	
116	200M BACKSTROKE	WOMEN	HEATS	
117	50M BUTTERFLY	MEN	HEATS	
118	4 x 50M MEDLEY MIXED	MIXED	HEATS	
102	400M INDIVIDUAL MEDLEY	MEN	T.FINALS	SLOWER HEATS IN THE MORNING
101	800M FREESTYLE	WOMEN	T.FINALS	SLOWER HEATS IN THE MORNING

18th Dec 2015 (Friday) – Day 1				
Finals Start Time: 6.30pm				
101	800M FREESTYLE	WOMEN	T.FINALS	FASTEST HEATS IN THE EVENING
102	400M INDIVIDUAL MEDLEY	MEN	T.FINALS	FASTEST HEATS IN THE EVENING
103	100M FREESTYLE	MEN	A & B FINALS	
104	200M FREESTYLE	WOMEN	A & B FINALS	
105	50M BREASTSTROKE	MEN	A & B FINALS	
<i>Victory Ceremony for #101,#102,#103 & #104</i>				
106	100M BREASTSTROKE	WOMEN	A & B FINALS	
107	100M BUTTERFLY	WOMEN	A & B FINALS	
108	100M BACKSTROKE	MEN	A & B FINALS	
109	50M BACKSTROKE	WOMEN	A & B FINALS	
110	200M BUTTERFLY	MEN	A & B FINALS	
<i>Victory Ceremony for 105,#106,#107,#108 & #109</i>				
111	200M INDIVIDUAL MEDLEY	WOMEN	A & B FINALS	
112	400M FREESTYLE	MEN	A & B FINALS	
113	50M FREESTYLE	WOMEN	A & B FINALS	
114	200M BREASTSTROKE	MEN	A & B FINALS	
115	100M INDIVIDUAL MEDLEY	MEN	A & B FINALS	
<i>Victory Ceremony for #110,#111,#112,#113 & #114</i>				
116	200M BACKSTROKE	WOMEN	A & B FINALS	
117	50M BUTTERFLY	MEN	A & B FINALS	
118	4 x 50M MEDLEY MIXED	MIXED	A & B FINALS	
<i>Victory Ceremony for #115,#116,#117 & #118</i>				

19th Dec 2015 (Saturday) – Day 2				
Heats Start Time: 9.30am				
Event No	Event			Remarks
203	100M FREESTYLE	WOMEN	HEATS	
204	200M FREESTYLE	MEN	HEATS	
205	50M BREASTSTROKE	WOMEN	HEATS	
206	100M BREASTSTROKE	MEN	HEATS	
207	100M BUTTERFLY	MEN	HEATS	
208	100M BACKSTROKE	WOMEN	HEATS	
209	50M BACKSTROKE	MEN	HEATS	
210	200M BUTTERFLY	WOMEN	HEATS	
211	200M INDIVIDUAL MEDLEY	MEN	HEATS	
212	400M FREESTYLE	WOMEN	HEATS	
213	50M FREESTYLE	MEN	HEATS	
214	200M BREASTSTROKE	WOMEN	HEATS	
215	100M INDIVIDUAL MEDLEY	WOMEN	HEATS	
216	200M BACKSTROKE	MEN	HEATS	
217	50M BUTTERFLY	WOMEN	HEATS	
218	4 x 50M FREESTYLE MIXED	MIXED	HEATS	
202	400M INDIVIDUAL MEDLEY	WOMEN	T.FINALS	SLOWER HEATS IN THE MORNING
201	1500M FREESTYLE	MEN	T.FINALS	SLOWER HEATS IN THE MORNING
19th Dec 2015 (Saturday) – Day 2				
Finals Start Time: 5.00pm				
201	1500M FREESTYLE	MEN	A & B FINALS	FASTEST HEATS IN THE EVENING
202	400M INDIVIDUAL MEDLEY	WOMEN	A & B FINALS	FASTEST HEATS IN THE EVENING
203	100M FREESTYLE	WOMEN	A & B FINALS	
204	200M FREESTYLE	MEN	A & B FINALS	
205	50M BREASTSTROKE	WOMEN	A & B FINALS	
<i>Victory Ceremony for #201, #202, #203 & #204</i>				

206	100M BREASTSTROKE	MEN	A & B FINALS	
207	100M BUTTERFLY	MEN	A & B FINALS	
208	100M BACKSTROKE	WOMEN	A & B FINALS	
209	50M BACKSTROKE	MEN	A & B FINALS	
210	200M BUTTERFLY	WOMEN	A & B FINALS	
<i>Victory Ceremony for #205,#206,#207,#208 & #209</i>				
211	200M INDIVIDUAL MEDLEY	MEN	A & B FINALS	
212	400M FREESTYLE	WOMEN	A & B FINALS	
213	50M FREESTYLE	MEN	A & B FINALS	
214	200M BREASTSTROKE	WOMEN	A & B FINALS	
215	100M INDIVIDUAL MEDLEY	WOMEN	A & B FINALS	
<i>Victory Ceremony for #210,#211,#212,#213 & #214</i>				
216	200M BACKSTROKE	MEN	A & B FINALS	
217	50M BUTTERFLY	WOMEN	A & B FINALS	
218	4 x 50M FREESTYLE MIXED	MIXED	A & B FINALS	
<i>Victory Ceremony for #215,#216,#217 & #218</i>				

13.0 TERMS & CONDITIONS

- 13.1 All Participants who are entered in the 5th Singapore National Swimming Championships (Short Course Meet) 2015 is deemed to have given written permission to the Organizers for the Organizers to collect analyse and collate any personal information relating to that Participant, as the Organizers may in their sole discretion deem fit, including without any limitation information for the Organizers' programme, planning, date-processing, statistical or risk-analysis, research, fund-raising and/ or, any other purposes in furtherance of the functions or powers of SSA.
- 13.2 Whilst reasonable precaution will be taken by the Organizers to ensure the Participants' safety, Participants take part in 5th Singapore National Swimming Championships (Short Course Meet) 2015 at their own risk and the Organizers will not be responsible or held liable for any injury or death howsoever arising from training for or during participation in 5th Singapore National Swimming Championships (Short Course Meet) 2015. Participants are strongly encouraged to consult their medical practitioner prior to registration and before the actual race day
- 13.3 In the event of harsh weather conditions that could cancel the 5th Singapore National Swimming Championships (Short Course Meet) 2015, SSA reserves the right not to refund entry fees or any other charges submitted by the teams and/ or individuals at the 5th Singapore National Swimming Championships (Short Course Meet) 2015.

14.0 KEY DATES

Date & Time	Event	Venue
9 Dec 2015	Closing Date for Entries Submission Note: Late entries will not be entertained	SSA Office or via email edwin.kwee@swimming.org.sg
10- 11 Dec 2015	Entries list by affiliates/ teams will be sent for verification	
11 Dec 2015	Deadline for Payment for Entries	
14 Dec 2015, 5.00pm	Preliminary Entries List (Psych Sheet) will be sent out to all participating affiliates/teams	
17 Dec 2015, 11.00am	Team Leaders Meeting	OCBC Aquatic Centre Technical Control Room
18 - 19 Dec 2015	5 th Singapore National Swimming C'ships (Short Course Meet) 2015	OCBC Aquatic Centre